

贴片共模电感-MnZn

AC Common Mode MnZn (SMDType)

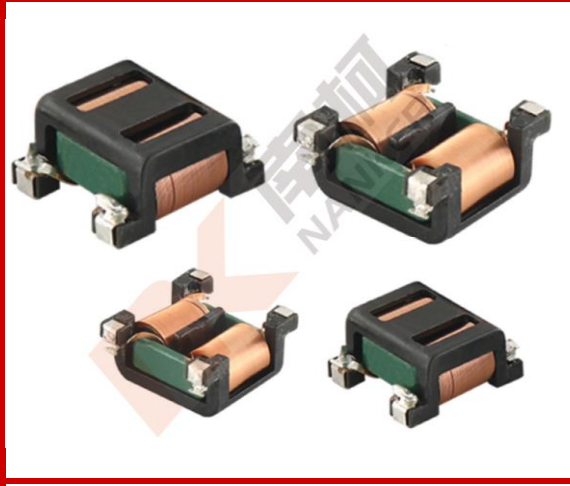

可定制不同感值&线径&尺寸

Custom make available for difference inductance, wire diameter and size

特性

Characteristics

磁芯材料: 锰锌

Core material: MnZn

中低频段高抑制率

High suppression rates of asymmetrical interferences at middle and low frequencies

对于射频及脉冲信号可以高稳定抑制

High interference stability against RF interference and burst signals

应用

Application

电力电子

Power electronics

电源线输入输出滤波器

Power line in- and output filter

脉冲信号的优化

Optimized for burst signals

产品品名介绍

Product Number Structure

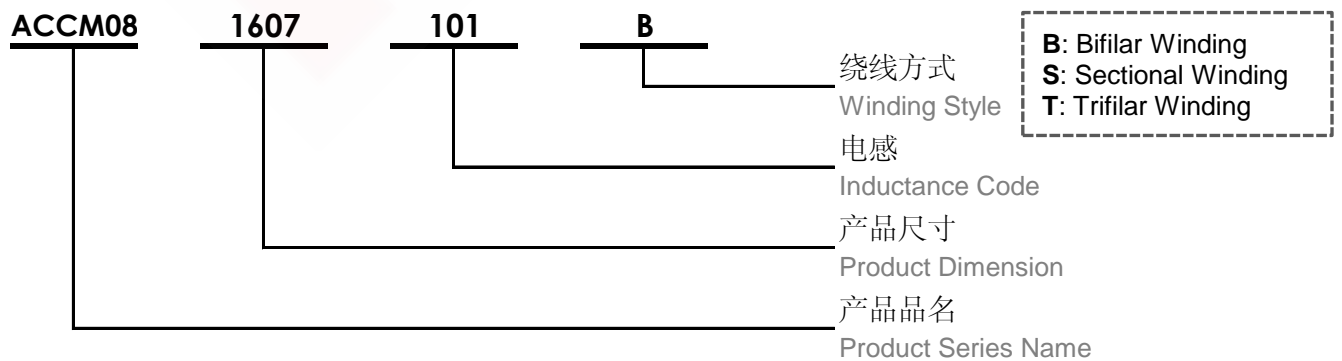

尺寸 Dimension (mm)

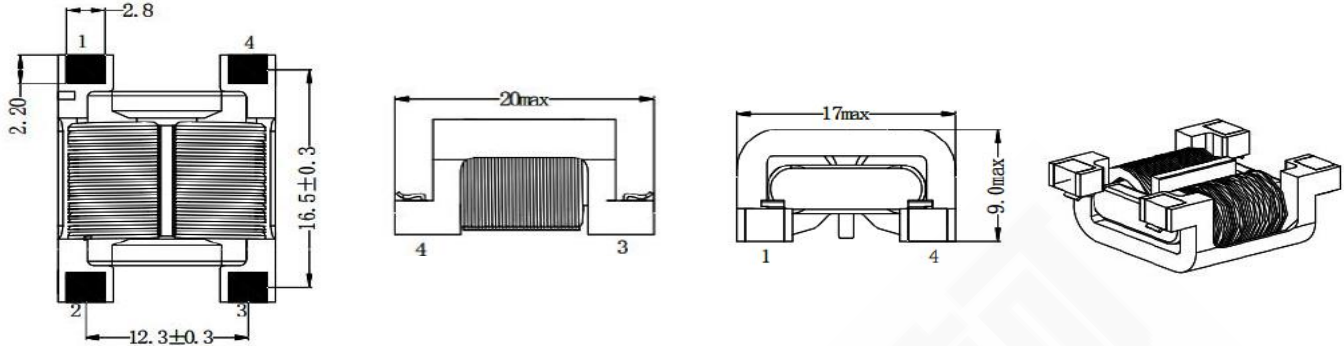

焊盘推荐 Land Pattern Recommended (mm)



示意图 Schematics



电性特性 Electrical Properties

型号 Part No.	电感 Inductance mH	温升电流 Rated Current I _r 40°C (A)	直流电阻 DCResistance DCR max (mΩ)	高压 Hi-Pot (V)	绕线方式 Winding Style
ACCM08-2017-502S	5.00 min	3.00	10.00	1,500	Sectional
ACCM08-2017-802S	8.00 min	1.80 ~ 2.20	150.00	1,500	Sectional
ACCM08-2017-103S	10.00 min	1.50 ~ 2.00	200.00	1,500	Sectional
ACCM08-2017-153S	15.00 min	1.00 ~ 1.50	220.00	1,500	Sectional

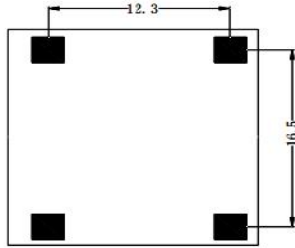
测试状态

Test Condition

- ☆ 电感测试条件为 1.0kHz / 0.25V
Inductance measure condition at 1.0kHz / 0.25V
- ☆ 工作温度: -40°C ~ +125°C
Operating Temperature: -40°C ~ +125°C



回流焊曲线图

Classification Reflow Profile for SMT Components

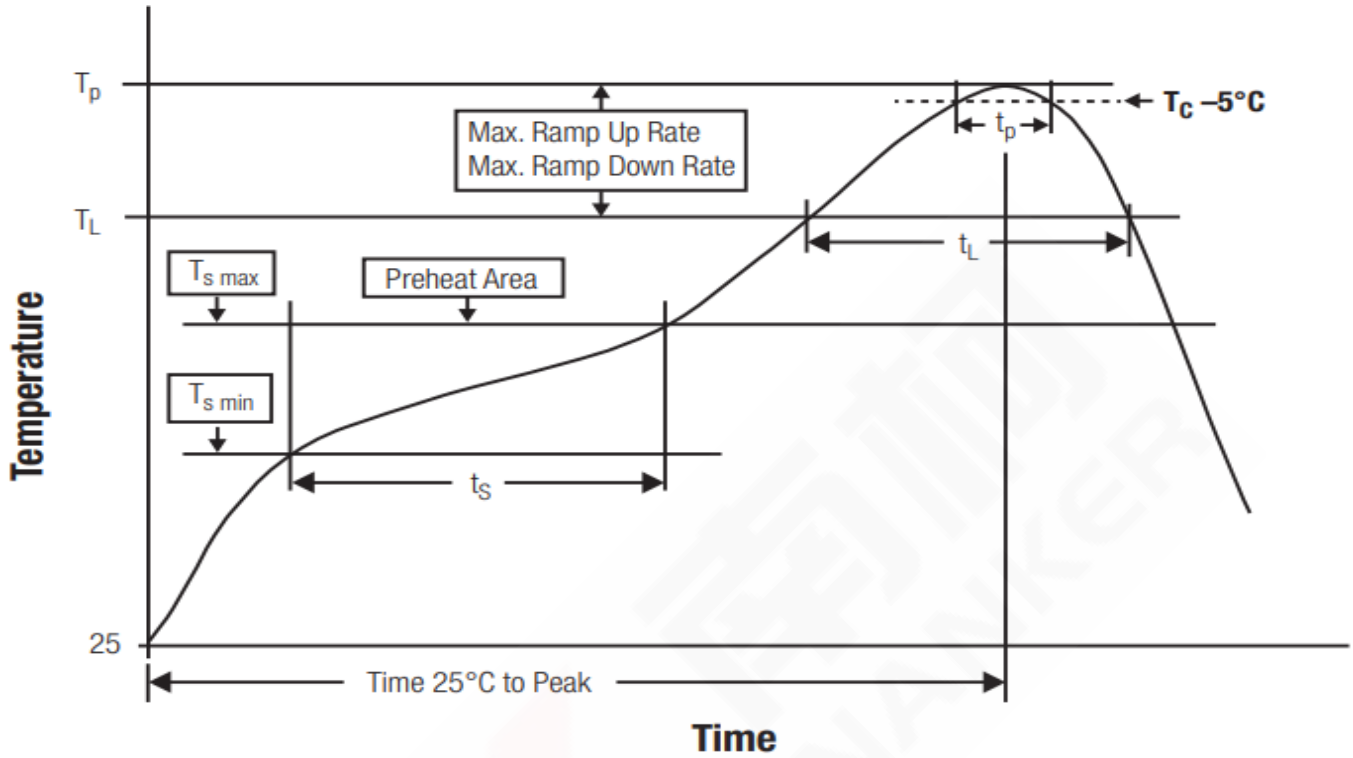

封装体峰值温度(Tp)分类

Classification Reflow Soldering Profile:

	封装厚度 Package Thickness	封装体积 Package Volume		
		<350 mm ³	350~2,000 mm ³	>2,000 mm ³
无铅装配 PB-Free Assembly	<1.60mm	260°C	260°C	260°C
	1.60~2.50mm	260°C	250°C	245°C
	>2.50mm	260°C	245°C	245°C

- ◆ 回流焊参照标准 IPC/JEDEC J-STD-020D。
Reflow is refer to standard IPC/JEDEC J-STD-020D.